

**TWO HOLE FLANGE MALE JACK**  
**FULL DETENT SOLDER TYPE CABLE .047**

**R222.251.022**

Series : SMP

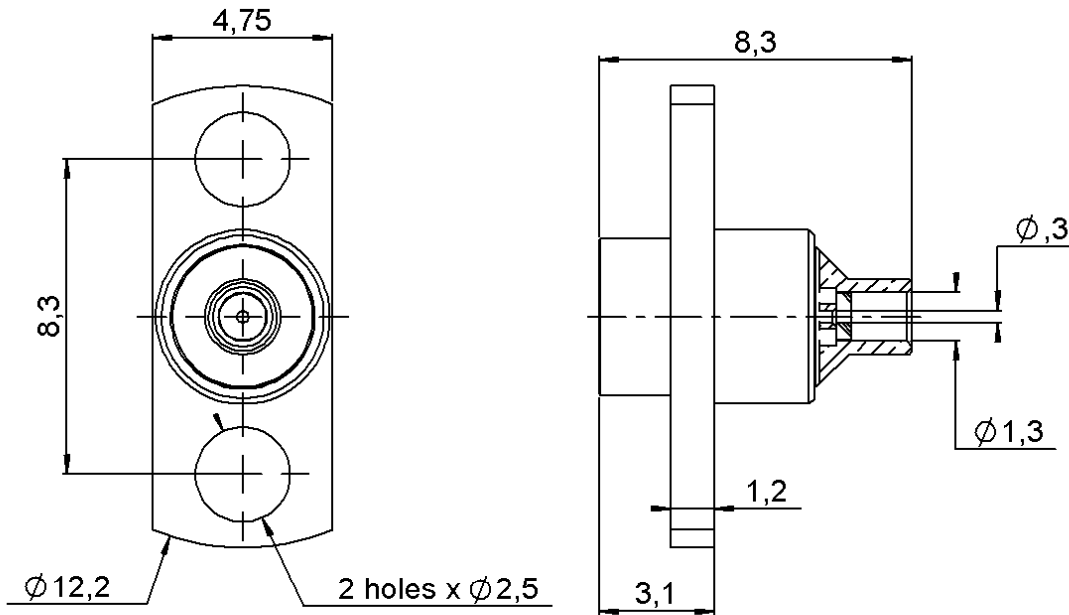

**PANEL CUT OUT**

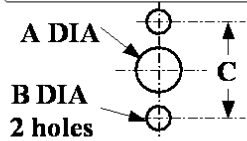

	mm	
	Maxi	mini
A	4.80	4.70
B	2.60	2.50
C	8.38	8.28

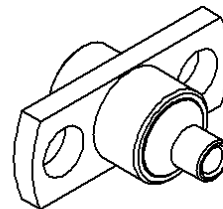
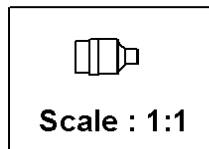

All dimensions are in mm.

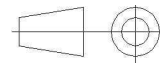

COMPONENTS	MATERIALS	PLATING (µm)
BODY	STAINLESS STEEL + BRASS	PASSIVATED+GOLD1.3 OVER NICKEL2
CENTER CONTACT	BERYLLIUM COPPER	GOLD 1.27 OVER NICKEL 1.27
OUTER CONTACT	-	-
INSULATOR	PTFE	-
GASKET	-	-
OTHERS PARTS	-	-
-	-	-
-	-	-

Issue : 0815 B

In the effort to improve our products, we reserve the right to make changes judged to be necessary.



**TWO HOLE FLANGE MALE JACK  
FULL DETENT SOLDER TYPE CABLE .047**

**R222.251.022**

Series : SMP

**PACKAGING**

Standard	Unit	Other
<b>100</b>	<b>'W' option</b>	<b>Contact us</b>

**SPECIFICATION**

**ELECTRICAL CHARACTERISTICS**

Impedance		<b>50</b> Ω
Frequency		<b>0-40</b> GHz
VSWR	<b>1.50 +</b>	<b>0,0000</b> x F(GHz) Maxi
Insertion loss		<b>0.12</b> √F(GHz) dB Maxi
RF leakage	- (	* - F(GHz)) dB Maxi
Voltage rating		<b>335</b> Veff Maxi
Dielectric withstanding voltage		<b>500</b> Veff mini
Insulation resistance		<b>5000</b> MΩ mini

**CABLE ASSEMBLY**

Stripping	a	b	c	d	e	f
mm	1,30	0,00	0,00	0,00	0,00	0,00

Assembly instruction :

Recommended cable(s)  
UT47 M17/151-00001

Characteristics indicated on this data sheet are those that can be achieved with the highest performance cable. Intrinsic limitations of the cable may diminish the performance of the assembly

Cable retention

- pull off	<b>45</b> N mini
- torque	<b>NA</b> N.cm

**MECHANICAL CHARACTERISTICS**

Center contact retention		
Axial force – Mating end	<b>NA</b>	N mini
Axial force – Opposite end	<b>NA</b>	N mini
Torque	<b>NA</b>	N.cm mini

Recommended torque		
Mating	<b>NA</b>	N.cm
Panel nut	<b>NA</b>	N.cm
Clamp nut	<b>NA</b>	N.cm
A/F clamp nut	<b>0,0000</b>	mm

Mating life	<b>100</b>	Cycles mini
Weight	<b>0,8000</b>	g

**TOOLING**

Part Number	Description	Hexagon
.	.	.
R282.740.030	SOLDERING MOUNTING	
R282.743.100	POSITIONER FOR SOLDERING SMP	
R282.744.254	POSITIONER FOR SOLDERING SMP	

**OTHER CHARACTERISTICS**

\*RF leakage -80dB DC- 3 GHz  
-65 dB 3- 26.5 GHz  
Compliant with MIL-STD-348

**ENVIRONMENTAL**

Operating temperature	<b>-65/+165</b>	° C
Hermetic seal	<b>NA</b>	Atm.cm3/s
Panel leakage	<b>NA</b>	

Issue : 0815 B

In the effort to improve our products, we reserve the right to make changes judged to be necessary.



**TWO HOLE FLANGE MALE JACK**  
**FULL DETENT SOLDER TYPE CABLE .047**

**R222.251.022**

Series : SMP

**COMPONENTS**

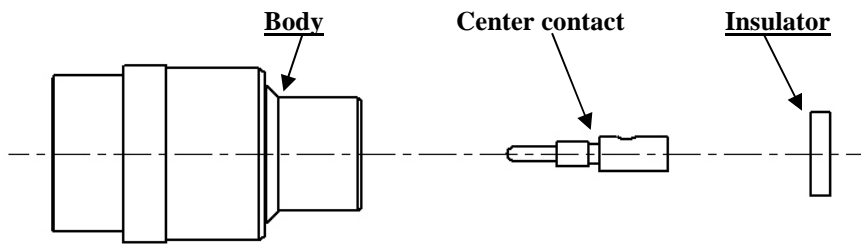

**STRIPPING CABLES**

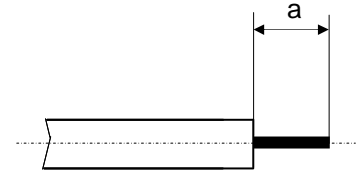

We recommend a thermal preconditioning cable

**1**

Strip the dielectric of the cable .  
 Clean the cable .  
 Soldering 180°C  
 Temperature stoking do not exceeded 250°C

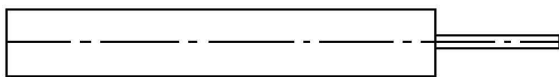

**2**

Screw the positioner onto the soldering jig.  
 Slide the center contact onto the cable inner conductor  
 against insulator.  
 Fit the cable assembly onto the soldering jig..  
 Solder the contact.

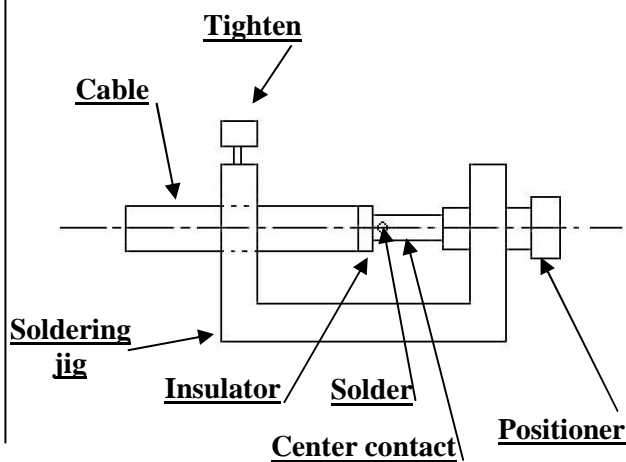

**3**

After cooling remove cable assembly from the jig.  
 Insert cable+centre contact in the connector.  
 Slide the positioner in the connector interface.  
 Slide cable into the connector body until it bottoms  
 against.  
 Slide positioner into the assembly.  
 Tighten.  
 Solder the body onto the cable.  
 After cooling remove cable assembly from the jig.

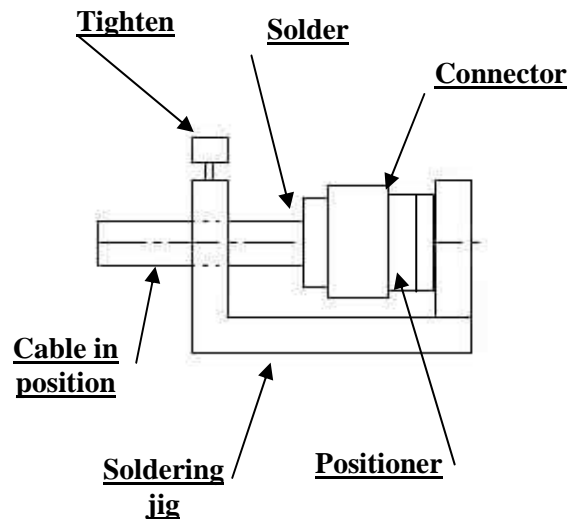

Issue : 0815 B

In the effort to improve our products, we reserve the right to make changes judged to be necessary.

